

REVISIONS				
ECN#	REV	DESCRIPTION	DATE	BY
	A	INITIAL RELEASE	1/5/17	HC

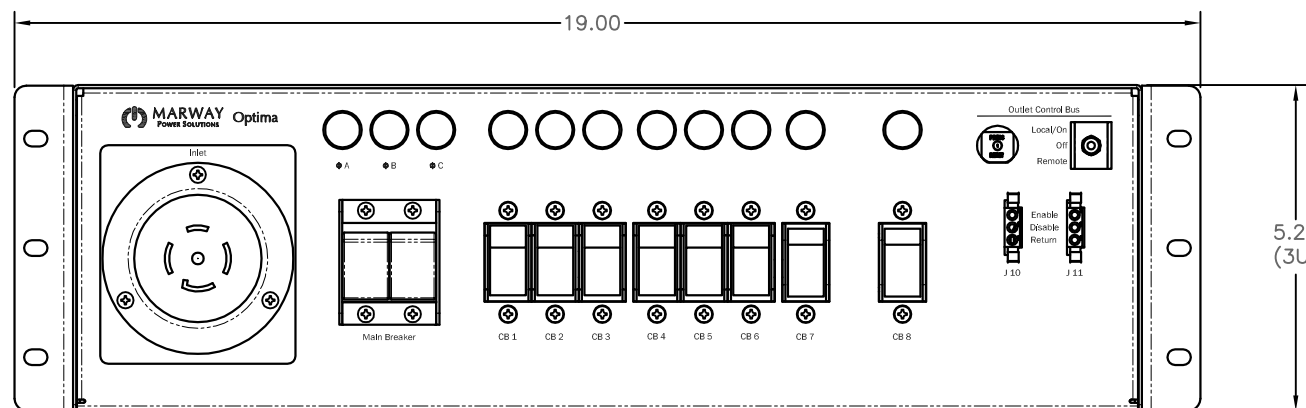

FRONT VIEW

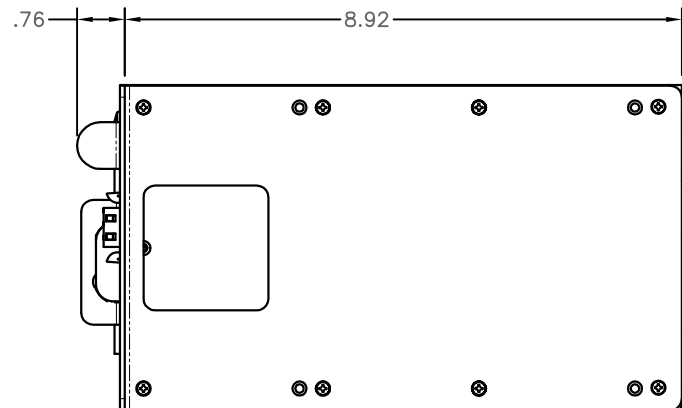

SIDE VIEW

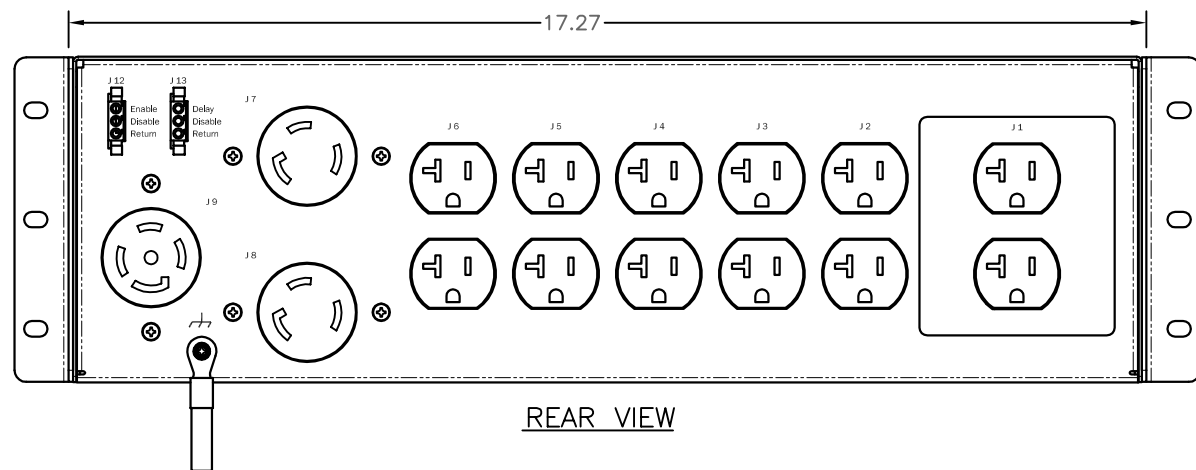

REAR VIEW

Configuration	Features	rEPO, EMI, Srg
	Layout	3 U
Input 1	Voltage	120/208 Vac, 3-Phase Wye, 50/60 Hz
	Max Current	30 Amps
	Max Load	2.88 KVA, 8.63 KVA
	Connection	L21-30P
	Voltage Monitor	None
	Current Monitor	None
Outlets	All Panels [1][2]	(2) 5-20R, 120V (10) 5-20R, 120V (S) (1) L21-30R, 120/208V (S) (2) L5-30R, 120V (S)
Protection	Spike/Surge Suppression [1]	Yes
	EMI Filter [1]	Yes
	Over Current [1]	(1) 30A Main Breaker (2) 30A Circuit Breaker (6) 20A Circuit Breaker
Env Sensors	Temperature	None
	Humidity	None
	Interlocks	None
	EPO	Remote EPO Type N.O./N.O.
Communications	Display	None
	Serial	None
	Ethernet	None
	Protocols	None

Physical	Dimensions	3 U x 19" W x 9" D
	Weight	17 lbs Estimated
	Materials	Chassis: Steel
	Finishes	Chassis: Painted Black, FrontPanel: Painted Black
Operating	Temperature	32°F to 122°F
	Humidity	5%RH to 85%RH
	Elevation	25,000 feet
Conformance	Warranty	http://www.marway.com/warranty
	Safety Certifications	UL
	Environment Certifications	None
Notes:		
[1] Certain details of the circuitry may only be revealed by the schematic (available separately)		
[2] S = switched, V = monitored voltage, A = monitored amps		

UNLESS OTHERWISE SPECIFIED DIMENSIONS ARE IN INCHES TOLERANCES ARE: ANGLES DECIMALS ± .5" .XX ± .03 XXX ± .010 DO NOT SCALE DRAWING	MATERIAL:	METAL NO.	SILK NO.	<p>1721 S. GRAND AVE. SANTA ANA, CA 92705 PH: (714) 917-6200 FX: (714) 917-6253</p> <p>SPECIFICATION DRAWING-- MPD 533007-000</p>	
	FINISH:	APPROVALS	DATE		
		DRAWN	1/5/17		
		CHECKED			
	APPROVED				
<small>PROPRIETARY NOTICE</small> THE INFORMATION CONTAINED IN THIS DRAWING IS THE SOLE PROPERTY OF MARWAY POWER SOLUTIONS. ANY REPRODUCTION IN PART OR AS A WHOLE WITHOUT THE WRITTEN PERMISSION OF MARWAY POWER SOLUTIONS IS STRICTLY PROHIBITED.		SIZE	CAGE CODE	DWG NO.	REV
		D	60955	533007-000	A
		SCALE	COMPUTER FILE NO.	P533007-000 REV A SHEET 1 OF 1	